

## Features

- ESD protection for high speed data lines to IEC61000-4-2
- ESD contact discharge typical 8KV, max 15KV
- ESD air discharge typical 15KV, max 25KV
- Extremely low capacitance
- Low leakage current
- Fast response time
- Bi-directional ESD protection

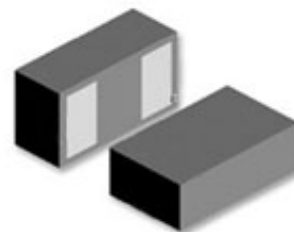

0402

## Applications

- High Definition Multi-Media Interface (HDMI)
- Digital Visual Interface (DVI)
- Display Port Interface (DP)/Unified Display Interface (UDI)
- Mobile Display Digital Interface (MDDI)
- Gigabit Ethernet
- USB2.0 and USB3.0
- IEEE1394 interface

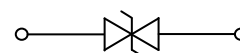

Schematic Diagram

## Absolute Maximum Ratings

Parameter	Symbol	Max.	Unit
Maximum Contact Discharge Voltage Per IEC61000-4-2	-	15KV	V
Maximum Air Discharge Voltage Per IEC61000- 4-2	-	25KV	V
Maximum Lead Temperature for Soldering During 10s	T <sub>L</sub>	260	°C
Maximum Operating Temperature	T <sub>OPER</sub>	-55 To +125	°C
Maximum Storage Temperature	T <sub>STG</sub>	-55 To +125	°C

**Electrical Characteristics** ( $T_A=25^\circ\text{C}$  unless otherwise specified)

Parameter	Symbol	Conditions	Min.	Typ.	Max.	Unit
Rated Voltage	$V_R$	-	-	-	15	V
Trigger Voltage	$V_T$	IEC61000-4-2 8KV contact discharge	-	300	-	V
Clamping Voltage	$V_C$	IEC61000-4-2 8KV contact discharge	-	35	-	V
Leakage Current	$I_L$	DC 15V shall be applied on component	-	0.01	0.1	$\mu\text{A}$
Capacitance	$C_P$	$V_R=0\text{V}$ , $f=1\text{MHz}$	-	0.05	-	pF

Note: 1 Trigger and clamping voltage are measured per IEC 61000-4-2, 8KV contact discharge method.

2 After reliability tests such as high temp storage, temp cycles, continuous ESD strike etc, the maximum leakage current is less than 10 $\mu\text{A}$ .

**ESD Clamping Test**

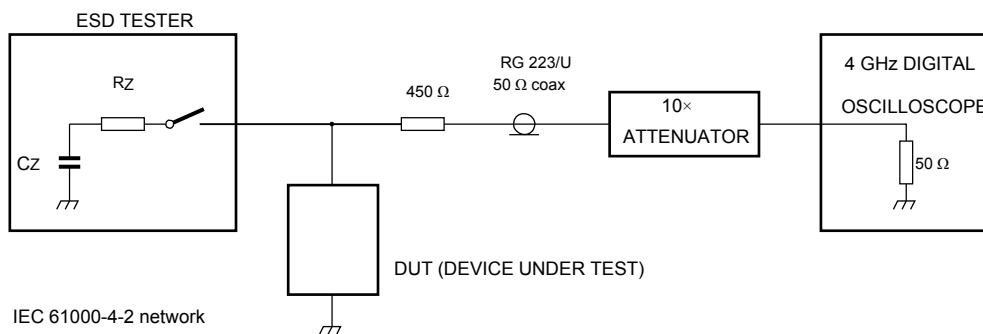

IEC 61000-4-2 network  
 $C_Z = 150 \text{ pF}$ ;  $R_Z = 330 \Omega$

**ESD Clamping Test Waveforms**

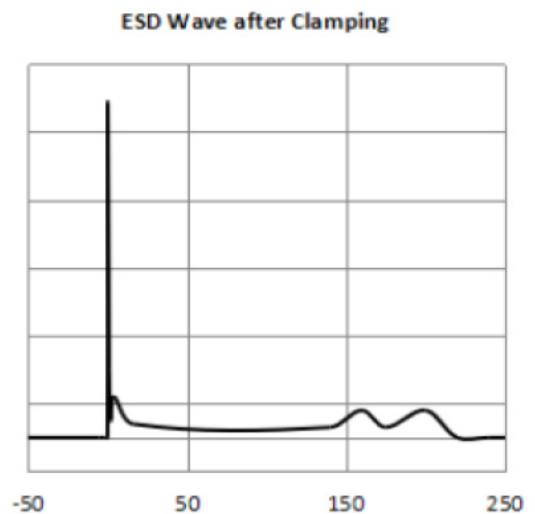
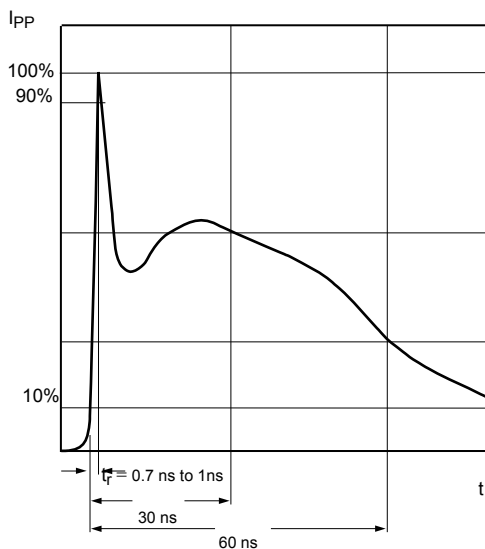

**Product Outline Dimensions**

**0402**

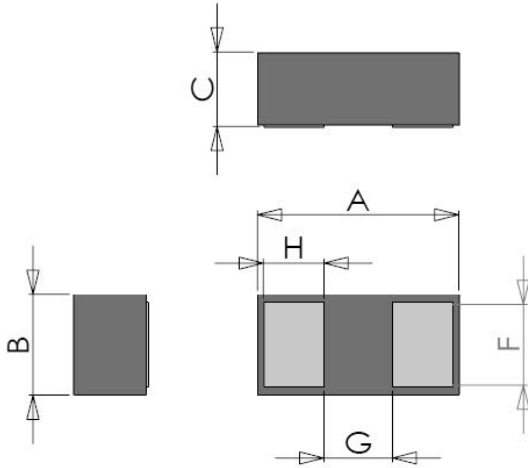

Symbol	Dimension			Unit
	Min	Typ	Max	
A	0.95	1.0	1.05	mm
B	0.45	0.50	0.55	
C	0.32	0.36	0.40	
H	0.28	0.30	0.32	
F	0.41	0.43	0.45	
G	0.32	0.34	0.36	

**Recommended Pad Layout**

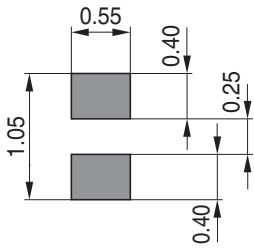

Dimensions in mm

Solder thickness 0.08 to 0.12mm

**Order Information**

Device	Package	Net Weight	Carrier	Quantity	HSF Status
GSEPD15B0005	0402	0.44 mg	Tape & Reel	10,000pcs/reel	RoHS compliant