

HS3AB thru HS3MB

Ultrafast Recovery Rectifiers
 Reverse Voltage 50V-1000V Forward Current 3.0 A

Features

- Glass passivated junction chip
- For surface mount applications
- Low forward voltage drop
- Low profile package
- Built-in stain relief, ideal for automated placement
- Fast switching for high efficiency
- Plastic package has Underwriters Laboratory Flammability Classification 94V-0
- Weight: 0.003 ounce, 0.093gram



Package: DO-214AA (SMB)



Applications

For use of general purpose rectifications in lighting, cellular phones, portable devices, power supplies and other consumer applications.

Maximum Ratings (T_A = 25°C unless otherwise noted)

Parameter	Symbol	HS3AB	HS3BB	HS3DB	HS3FB	HS3GB	HS3JB	HS3KB	HS3MB	Unit
Maximum Repetitive Peak Reverse Voltage	V _{RRM}	50	100	200	300	400	600	800	1000	V
Maximum RMS Voltage	V _{RMS}	35	70	140	210	280	420	560	700	V
Maximum DC Blocking Voltage	V _{DC}	50	100	200	300	400	600	800	1000	V
Maximum Average Output Rectified Current	I _{F(AV)}	3.0								A
Peak Forward Surge Current (8.3 ms single half sine-wave superimposed on rated load)	I _{FSM}	150								A
Operating Junction and Storage Temperature Range	T _J , T _{STG}	-55 to +150								°C

Electrical Characteristics (T_A = 25°C unless otherwise noted)

Parameter	Test Conditions	Symbol	HS3AB	HS3BB	HS3DB	HS3FB	HS3GB	HS3JB	HS3KB	HS3MB	Unit
Maximum Instantaneous Forward Voltage	I _F =3A	V _F	1.0			1.3		1.7			V
Maximum DC Reverse Current at Rated DC Blocking Voltage	T _A =25°C T _A =100°C	I _R	10				200				μA
Maximum Reverse Recovery Time	I _F =0.5A, I _R =1.0A, I _{RR} =0.25A	t _{rr}	50				75				ns
Typical Junction Capacitance	4.0 V, 1 MHz	C _J	80				50				pF

Ratings and Characteristics Curves ($T_A = 25^\circ\text{C}$ unless otherwise noted)

FIG.1- REVERSE RECOVERY TIME CHARACTERISTIC AND TEST CIRCUIT DIAGRAM FIG.2- MAXIMUM FORWARD CURRENT DERATING CURVE

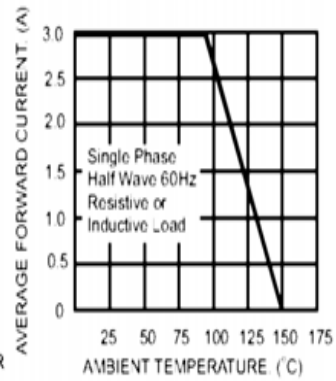
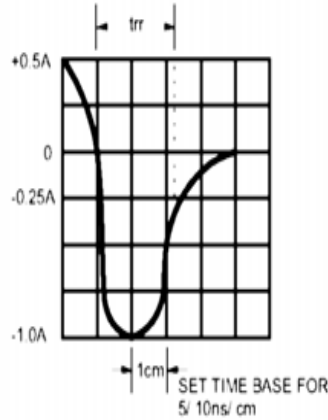
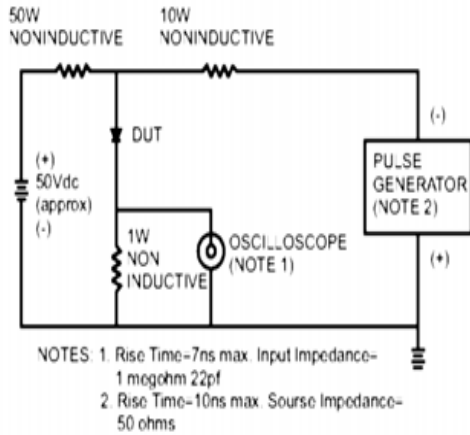

FIG.3- TYPICAL REVERSE CHARACTERISTICS

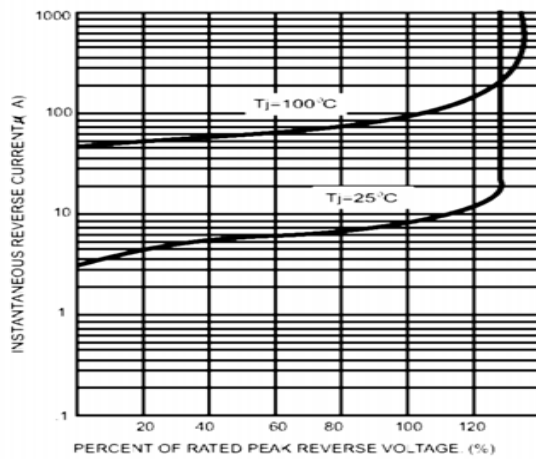

FIG.4- TYPICAL INSTANTANEOUS FORWARD CHARACTERISTICS

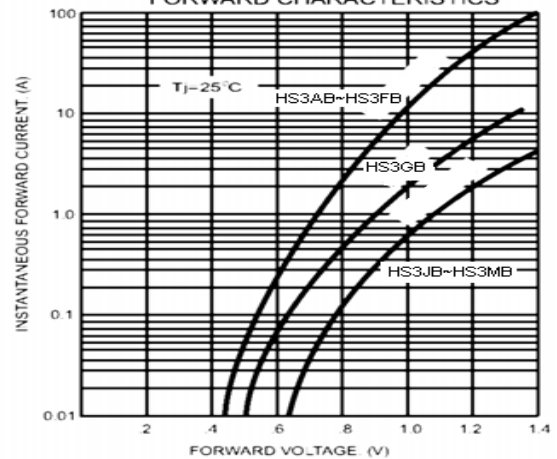

FIG.5- MAXIMUM NON-REPETITIVE FORWARD SURGE CURRENT

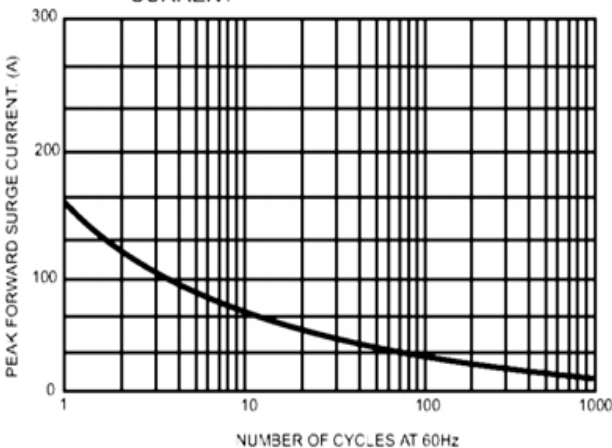
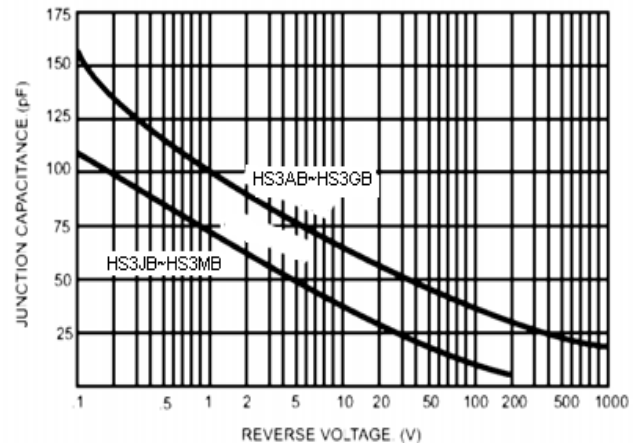

FIG.6- TYPICAL JUNCTION CAPACITANCE



Package Outline Dimensions

in inches (millimeters)

Package: SMB (DO-214AA)

