

Features

- General purpose switching and amplification.

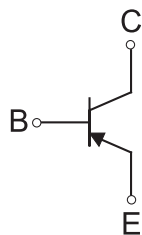

Schematic Diagram

1. Emitter
2. Base
3. Collector

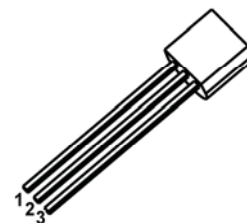

TO-92

Absolute Maximum Ratings ($T_A=25^{\circ}\text{C}$ unless otherwise noted)

Parameter	Symbol	Max.	Unit
Collector-Base Voltage	V_{CB0}	-80	V
Collector-Emitter Voltage	V_{CE0}	-80	V
Emitter-Base Voltage	V_{EB0}	-4	V
Collector Current-Continuous	I_C	-0.5	A
Collector Power Dissipation	P_D	625	mW
Thermal Resistance Junction to Ambient	$R_{\theta JA}$	200	$^{\circ}\text{C}/\text{W}$
Operation Junction Temperature Range	T_J	-55 To +150	$^{\circ}\text{C}$
Storage Temperature Range	T_{STG}	-55 To +150	$^{\circ}\text{C}$

Electrical Characteristics ($T_A=25^{\circ}\text{C}$ unless otherwise noted)

Parameter	Symbol	Conditions	Min.	Max.	Unit
Collector-Base Breakdown Voltage	$V_{(BR)CB0}$	$I_C=-0.1\text{mA}, I_E=0$	-80	-	V
Collector-Emitter Breakdown Voltage	$V_{(BR)CE0}$	$I_C=-1\text{mA}, I_B=0$	-80	-	V
Emitter-Base Breakdown Voltage	$V_{(BR)EB0}$	$I_E=-100\mu\text{A}, I_C=0$	-4	-	V
Collector Cut-Off Current	I_{CBO}	$V_{CB}=-80\text{V}, I_E=0$	-	-0.1	μA
	I_{CEO}	$V_{CE}=-60\text{V}, I_B=0$	-	-0.1	μA
Emitter Cut-Off Current	I_{EBO}	$V_{EB}=-4\text{V}, I_C=0$	-	-0.1	μA
DC Current Gain	h_{FE1}	$V_{CE}=-1\text{V}, I_C=-10\text{mA}$	100	-	-
	h_{FE2}	$V_{CE}=-1\text{V}, I_C=-100\text{mA}$	100	-	-
Collector-Emitter Saturation Voltage	$V_{CE(sat)}$	$I_C=-100\text{mA}, I_B=-10\text{mA}$	-	-0.25	V
Base-Emitter Saturation Voltage	$V_{BE(sat)}$	$I_C=-100\text{mA}, V_{CE}=-1\text{V}$	-	-1.2	V
Transition Frequency	f_T	$V_{CE}=-1\text{V}, I_C=-100\text{mA}, f=100\text{MHz}$	50	-	MHz

Typical Characteristic Curves

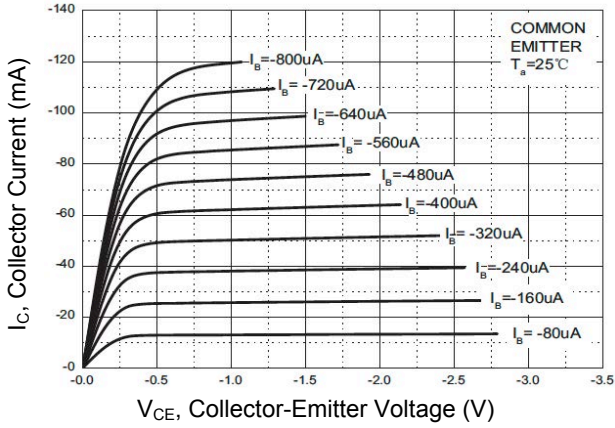

Figure 1. Static Characteristic

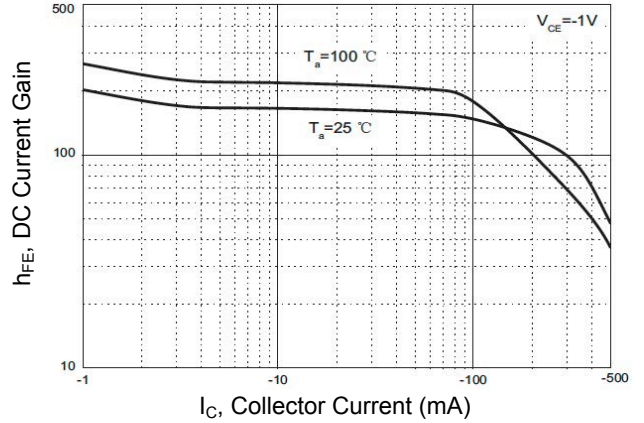

Figure 2. DC Current Gain vs. Collector Current

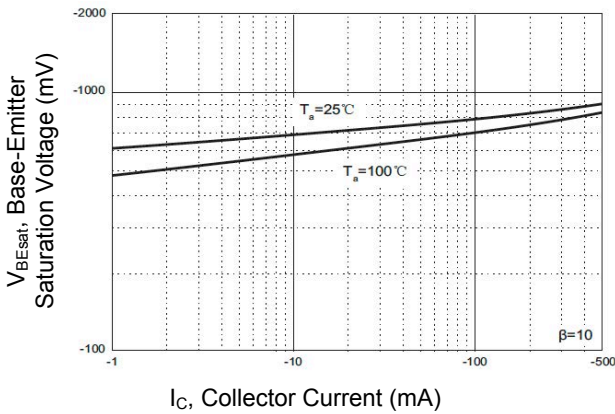

Figure 3. Base Emitter Saturation Voltage vs. Ic

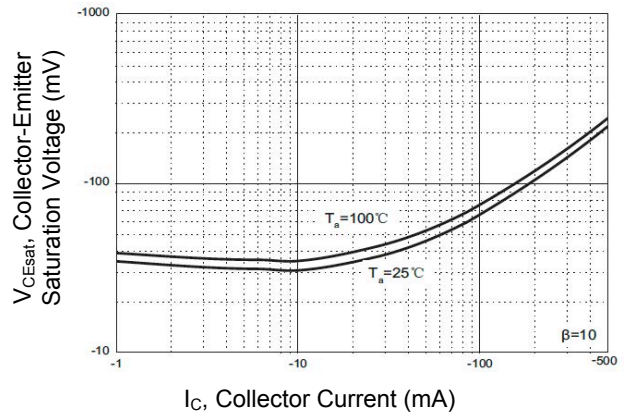

Figure 4. Collector Emitter Saturation Voltage vs. Ic

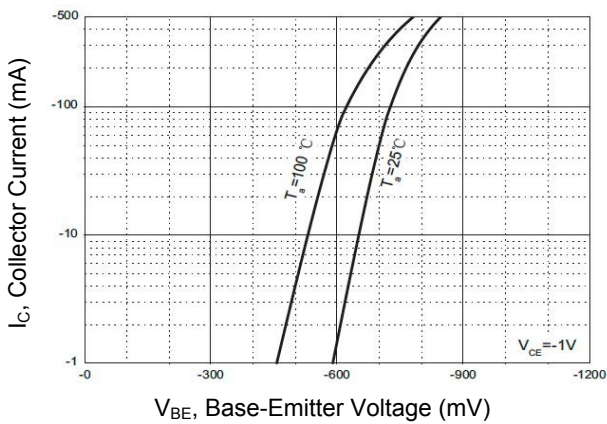

Figure 5. Ic vs. Base Emitter Voltage

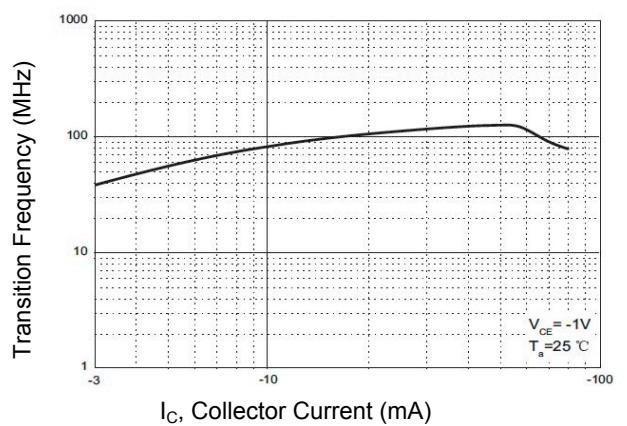

Figure 6. Transition Frequency vs. Ic

Typical Characteristic Curves

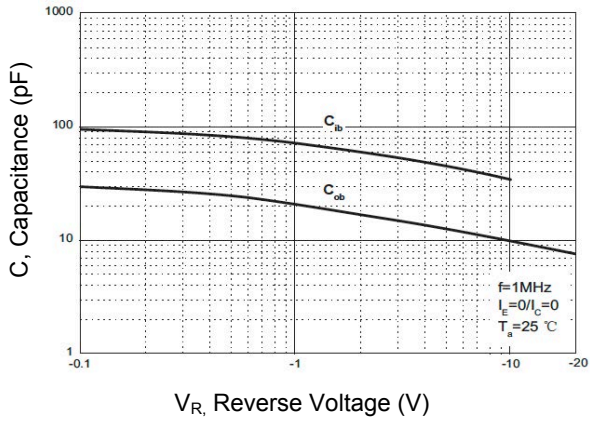

Figure 7. Capacitance Characteristics

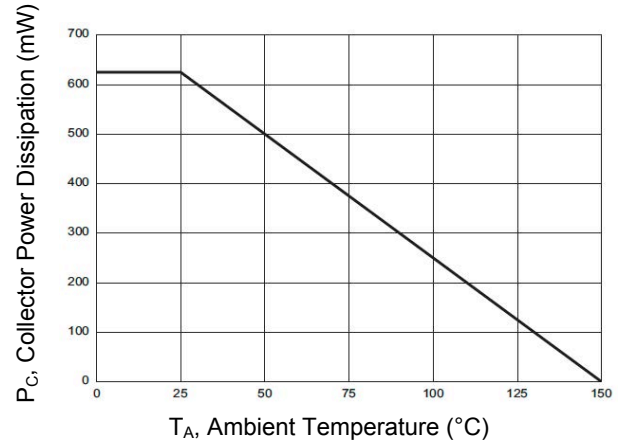
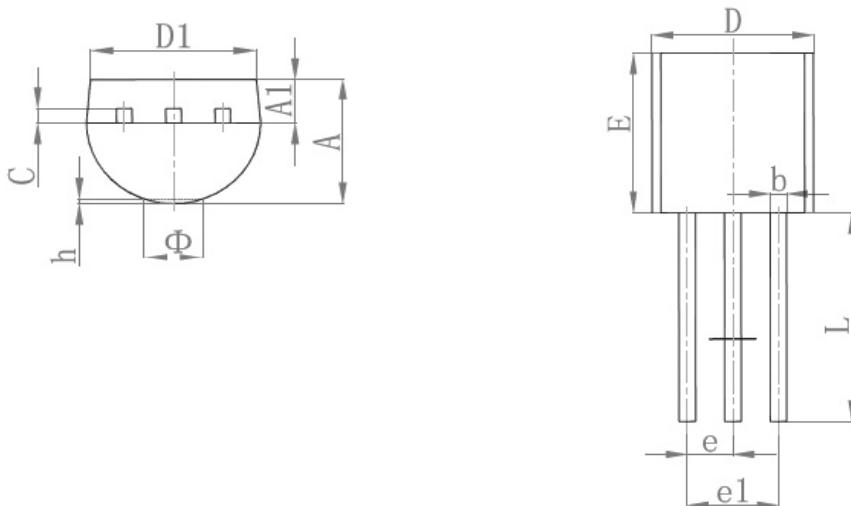

Figure 8. Power Derating

Package Outline Dimensions (TO-92)



Symbol	Dimensions in Millimeters		Dimensions in Inches	
	Min	Max	Min	Max
A	3.300	3.700	0.130	0.146
A1	1.100	1.400	0.043	0.055
b	0.380	0.550	0.015	0.022
c	0.360	0.510	0.014	0.020
D	4.300	4.700	0.169	0.185
D1	3.430	-	0.135	-
E	4.300	4.700	0.169	0.185
e	1.270 TYP		0.050 TYP	
e1	2.440	2.640	0.096	0.104
L	14.100	14.500	0.555	0.571
Φ	-	1.600	-	0.063
h	0.000	0.380	0.000	0.015

Recommended Pad Layout

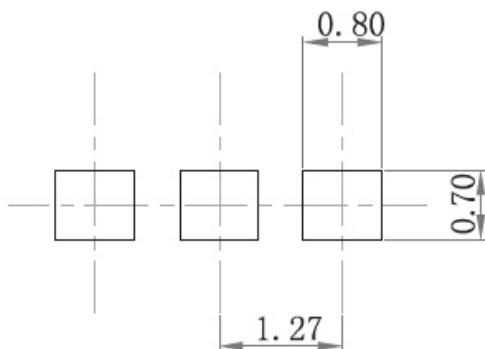

Note:

1. Controlling dimension: in millimeters.
2. General tolerance: $\pm 0.05\text{mm}$.
3. The pad layout is for reference purposes only.

Order Information

Device	Package	Packing Method	Quantity
GSMPSA56	TO-92	Tape	2,000 pcs / Box